



LIVE CENTER



주식회사 포인트 테크
韓國GG頂尖製造會社
POINT TECH CO., LTD.



POINT TECH



How Point Tech is working for our valued customers

As a leading manufacturer of high quality live and dead centers we are providing the best quality at the lowest price to our customers. Each Point Tech center is manufactured to achieve 100% customer satisfaction, and we are selling not only high quality products but also our pride to customers.

Every center is tested at least 4 times to ensure our customer the highest quality available in the market today.

PointTech products are sold throughout the world by our sales representatives. If you do not know how to purchase our products, give us a call at +82 62 942 0451 or E-mail (point@pointtec.com) and we will provide you the local dealers.

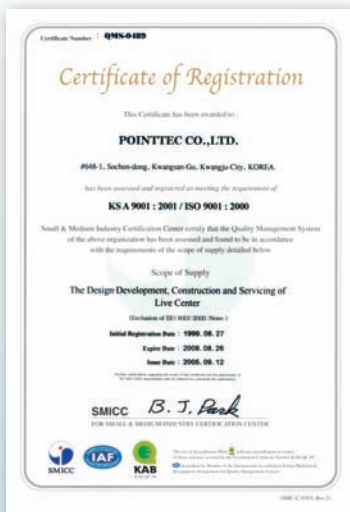

Company History

- Mar. 1984 : Established the GIGONG SERVICE CO., LTD.
- Aug. 1988 : Appointed as the 2nd Class Quality control company (by Ministry of Industrial Advancement Administration)
- Jul. 1990 : Established the GIGONG INDUSTRIAL CO., LTD as a branch factory.
- Dec. 1990 : Selected as a Technologically Advanced Enterprise by Ministry of Trade and Industry.
- Aug. 1996 : Selected as a Superior Enterprise by the Citizens National Bank.
- Jun. 1997 : Establishment of Annexed Technological Research Center.
- Feb. 1998 : Selected as a Promising Small & Medium Enterprise for Exportation Institute for Promoting Small & Medium Enterprise.
- Jan. 1999 : Formed into another company as POINT TECH., INC.
- Dec. 1999 : Approved "S" mark by Korean Occupational Safety & Health Agency.
- Jun. 2000 : Confirmed venture by the Research and Development Department of Small and Medium Business Administration.
- Feb. 2001 : Nominated as a special exception of military service by the Office of Military Manpower.
- Feb. 2003 : Europe export open a export.
- Apr. 2004 : POINT TECH CO., LTD. CHINA office open.
- Jun. 2005 : Front and Rear Direction Movement the Precision Live Center a Patent Application.
- Jan. 2006 : HS Type a Lige size Live Center a Precision Grinding Production.
- Mar. 2007 : BS Type Precision High Processing Production.
- Dec. 2013 : Factory transfer to high tech industrial complex.
- Mar. 2014 : Receive a exemplary taxpayer citation – National Tax Service.





Morse Taper

CNC HIGH SPEED LIVE CENTERS

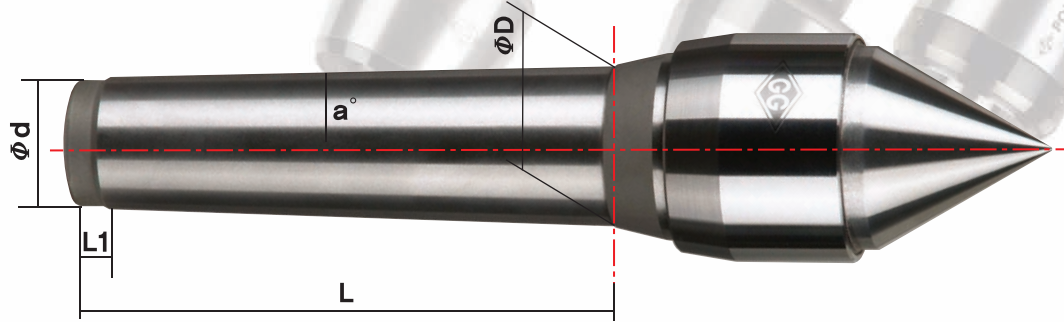

Dimension

Unit : mm

Morse Taper(MT)	ϕD (Gauge line)	ϕd	a°	L	L1
2	$\phi 17.780$	14	1 ° 25'50"	64	4
3	$\phi 23.825$	19	1 ° 26'16"	79	7
4	$\phi 31.267$	25	1 ° 29'15"	100	9
5	$\phi 44.399$	35	1 ° 30'26"	128	9
6	$\phi 63.348$	51	1 ° 29'36"	179	12
7	$\phi 83.058$	65	1 ° 29'22"	248	12

Special Type



POINTTECH offer the special shape of live or dead-center internationally. Head company's technical design team will promptly contact with end-user. And we offer you the drawing includes customer's requirements. POINTTECH's special model guarantee Quality, Fast delivery, Reasonable price.

Feel free to contact by e-mail 'point@pointtec.com'



Brown & Sharpe, Jarno and Straight Shanks Available

CNC HIGH SPEED LIVE CENTERS



- BN-TYPE / 6
- BNC-TYPE / 7
- BNL30-TYPE / 8
- BNL30A-TYPE / 9

DRAW-OFF NUT LIVE CENTERS



- BNN-TYPE / 10
- BNNC-TYPE / 11

HIGH SPEED LIVE CENTERS



- BNH-TYPE / 12
- BNHC-TYPE / 13
- BNHL30-TYPE / 14
- BNHL30A-TYPE / 15

HIGH SPEED LIVE CENTERS



- BS-TYPE / 16
- BSC-TYPE / 17
- BSL30-TYPE / 18
- BSL30A-TYPE / 19

SUPER HIGH SPEED LIVE CENTERS



- BHS-TYPE / 20
- BHSC-TYPE / 21
- BHSL30-TYPE / 22
- BHSL30A-TYPE / 23

INTER CHANGEABLE POINTS LIVE CENTERS



- BNI-TYPE / 24
- BNI-POINT / 25

HEAVY DUTY LIVE CENTERS



- TN-TYPE / 26
- TNC-TYPE / 27

WATER PROOF LIVE CENTERS



- WP-TYPE / 28
- WPC-TYPE / 29
- WPL30-TYPE / 30
- WPL30A-TYPE / 31

60 BULL HEAD LIVE CENTERS



- BP60-TYPE / 32
- BP60A-TYPE / 33

80 BULL HEAD LIVE CENTERS



- BP80-TYPE / 34

DEAD CENTER

- DEAD CENTER / 35

FACE DRIVER

- FACE DRIVER / 36
- FACE DRIVER / 37
- FD-SPECIAL TYPE / 38

EASY THRUST ADJUSTMENT

- SD-TYPE / 39

BALUE-TURN LIVE CENTERS



- BB-TYPE / 40
- BBL30-TYPE / 41

VERY HEAVY DUTY LIVE CENTER



- HS-TYPE / 42
- HSN-TYPE / 43

BN-TYPE



FEATURES ;

- Accuracy guaranteed to 0,003mm TIR (0,0001").
- Excellent for engine lathes and CNC lathes.
- Heat-treated point to HRC 60±2.
- High performance lip seal and deflected shaft design protects bearing space(Double Angular Contact bearing) from invasion by dust and coolant.
- Heat-treated body for extra strength, rigidity and long life.

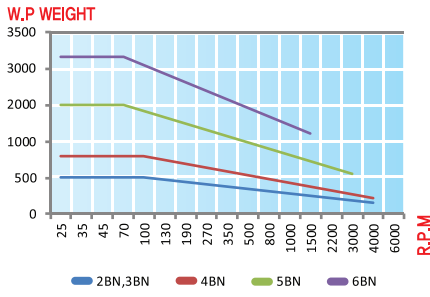

BN type technical data

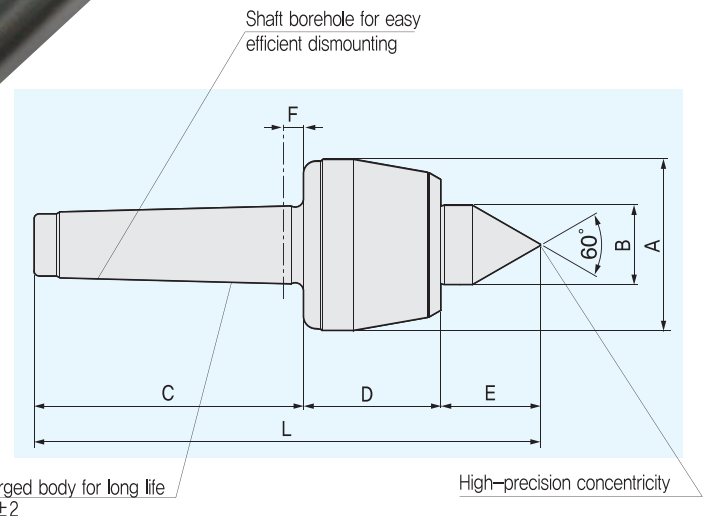

Dimension

01	1	0	0	MT	Unit : mm, kg							
MODEL	MT	A	B	C	D	E	F	L	W.P Weight	Max, R.P.M	Weight	Max, Run Out
011002	2	50	25	68	43,5	29,5	6	141	500	5,000	0,7	0,003
011003	3	50	25	85	43,5	29,5	6	158	500	5,000	0,8	0,003
011004	4	69	32	108	55	40	8	203	800	3,800	1,85	0,003
011005	5	88	40	136	70	50,5	8	256,3	2,000	3,000	4,2	0,003
011006	6	105	50	189	81,5	57,5	10	328	3,500	2,800	8,7	0,005

BNC-TYPE



FEATURES ;

- Accuracy guaranteed to 0,003mm TIR (0,0001").
- Excellent for engine lathes and CNC lathes.
- Heat-treated point to HRc 90±5.
- High performance lip seal and deflected shaft design protects bearing space(Double Angular Contact bearing) from invasion by dust and coolant.
- Heat-treated body for extra strength, rigidity and long life.

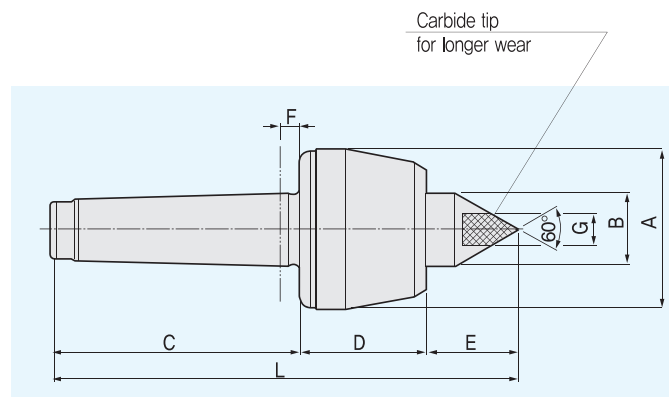

CNC HIGH SPEED LIVE CENTERS WITH CARBIDE TIPPED POINT

Dimension

01	2	0	0	MT	Unit : mm, kg								
MODEL	MT	A	B	C	D	E	F	G	L	W,P Weight	Max, R.P.M	Weight	Max, Run Out
012002	2	50	25	68	43,5	29,5	6	10	141	500	5,000	0,7	0,003
012003	3	50	25	85	43,5	29,5	6	10	158	500	5,000	0,8	0,003
012004	4	69	32	108	55	40	8	14	203	800	3,800	1,85	0,003
012005	5	88	40	136	70	50,5	8	18	256,3	2,000	3,000	4,2	0,003
012006	6	105	50	189	81,5	57,5	10	30	328	3,500	2,800	8,7	0,005

BNL30-TYPE



FEATURES ;

- Accuracy guaranteed to 0,003mm TIR (0,0001").
- Excellent for engine lathes and CNC lathes.
- Heat-treated point to HRC 60±2.
- High performance lip seal and deflected shaft design protects bearing space(Double Angular Contact bearing) from invasion by dust and coolant.
- Heat-treated body for extra strength, rigidity and long life.

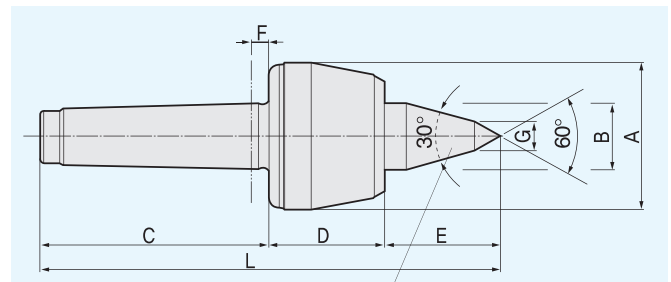
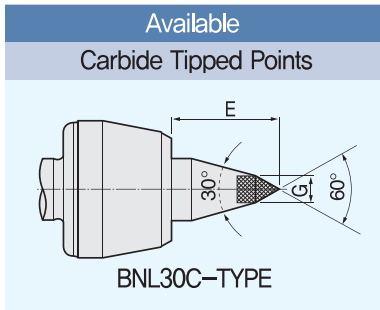

30° point is specially shaped for improved tool clearance

Dimension

01	3	0	0	MT										Unit : mm, kg	
MODEL	MT	A	B	C	D	E	F	G	L	W,P Weight	Max, R,P,M	Weight	Max, Run Out		
013002	2	50	25	68	43,5	40	6	10	151,5	500	5,000	0,7	0,003		
013003	3	50	25	85	43,5	45	6	12	175,5	500	5,000	0,8	0,003		
013004	4	69	32	108	55	53	8	14	216	500	3,800	1,9	0,003		
013005	5	88	40	136	70	65	8	16	271	1,500	3,000	4,4	0,003		
013006	6	105	50	189	81,5	77,5	10	18	348	2,500	2,800	8,7	0,005		

BNL30A-TYPE



FEATURES ;

- Accuracy guaranteed to 0.003mm TIR (0.0001").
- Excellent for engine lathes and CNC lathes.
- Heat-treated point to HRC 60±2.
- High performance lip seal and deflected shaft design protects bearing space(Double Angular Contact bearing) from invasion by dust and coolant.
- Heat-treated body for extra strength, rigidity and long life.

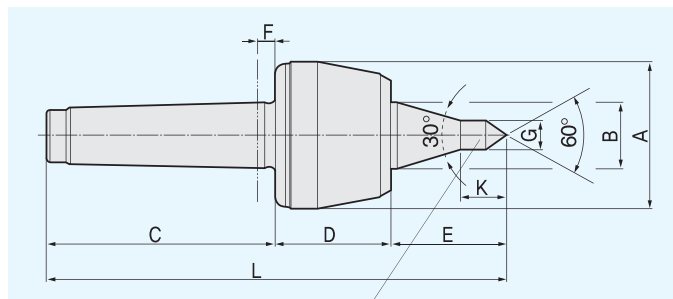
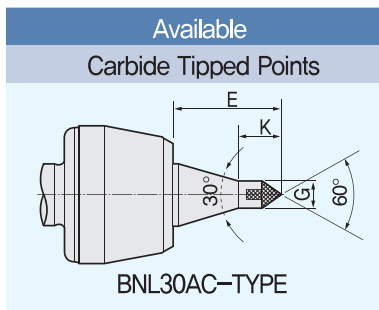

Elongated center point is specially shaped for improved tool clearance(Diagram)

Dimension

01	5	0	0	MT											Unit : mm, kg	
MODEL	MT	A	B	C	D	E	F	G	K	L	W.P Weight	Max, R.P.M	Weight	Max, Run Out		
015002	2	50	25	68	43.5	50	6	10	19	161.5	500	5,000	0.7	0.003		
015003	3	50	25	85	43.5	50	6	10	19	178.5	500	5,000	0.8	0.003		
015004	4	69	32	108	55	63.5	8	12.5	23.5	226.5	500	3,800	1.9	0.003		
015005	5	88	40	136	70	80	8	12.5	23.5	286	1,500	3,000	4.4	0.003		
015006	6	105	50	189	81.5	105	10	14	30	375.5	2,500	2,800	8.7	0.005		

BNN-TYPE



FEATURES ;

- Accuracy guaranteed to 0,003mm TIR (0,0001").
- Excellent for engine lathes and CNC lathes.
- Heat-treated point to HRc 60±2.
- High performance lip seal and deflected shaft design protects bearing space (Double Angular Contact bearing) from invasion by dust and coolant.
- Heat-treated body for extra strength, rigidity and long life.
- Draw-off nut type, (Help to easy release from tail-stock)

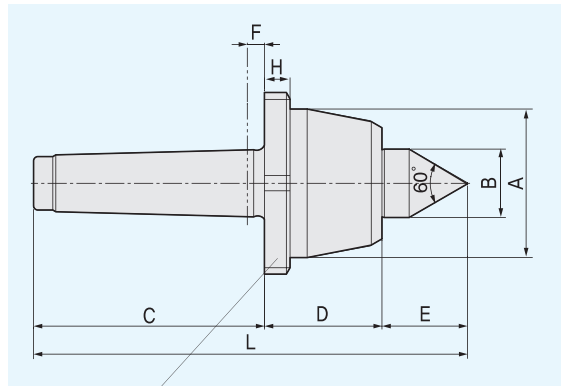

Draw-off nut for easily take out

Dimension

02	1	0	0	MT	Unit : mm, kg										
MODEL	MT	A	B	C	D	E	F	H	L	W,P Weight	Max, R.P.M	Weight	Max, Run Out	AN NUT NO.	
021002	2	50	25	68	43.5	29.5	6	10	141	500	5,000	1	0,003	AN 09	
021003	3	50	25	85	43.5	29.5	6	10	158	500	5,000	1	0,003	AN 09	
021004	4	69	32	108	55	40	8	12	203	800	3,800	2.1	0,003	AN 13	
021005	5	88	40	136	70	50.5	8	16	256.5	2,000	3,000	5	0,003	AN 17	
021006	6	105	50	189	81.5	57.5	10	18	328	3,500	2,800	10,5	0,005	AN 20	

BNNC-TYPE



FEATURES ;

- Accuracy guaranteed to 0,003mm TIR (0,0001").
- Excellent for engine lathes and CNC lathes.
- Heat-treated point to HRc 90±5.
- High performance lip seal and deflected shaft design protects bearing space(Double Angular Contact bearing) from invasion by dust and coolant.
- Heat-treated body for extra strength, rigidity and long life.
- Draw-off nut type. (Help to easy release from tail-stock)

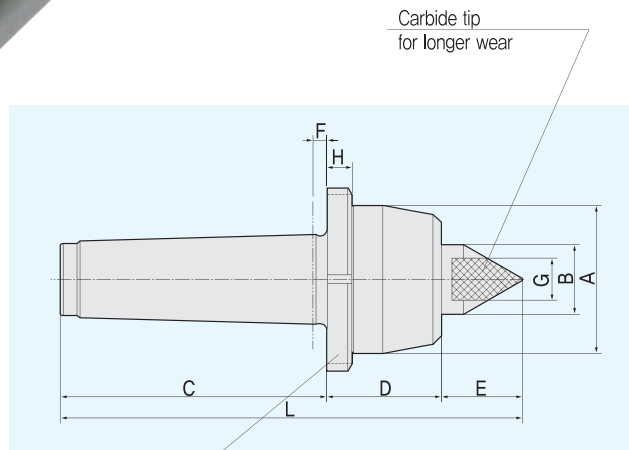

Dimension

02	2	0	0	MT	Unit : mm, kg											
MODEL	MT	A	B	C	D	E	F	H	G	L	W,P Weight	Max, R,P,M	Weight	Max, Run Out	AN NUT NO.	
022002	2	50	25	68	43.5	29.5	6	10	10	141	500	5,000	1	0,003	AN 09	
022003	3	50	25	85	43.5	29.5	6	10	10	158	500	5,000	1	0,003	AN 09	
022004	4	69	32	108	55	40	8	12	14	203	800	3,800	2.1	0,003	AN 13	
022005	5	88	40	136	70	50.5	8	16	18	256.5	2,000	3,000	5	0,003	AN 17	
022006	6	105	50	189	81.5	57.5	10	18	30	328	3,500	2,800	10.5	0,005	AN 20	

BNH-TYPE



FEATURES ;

- Accuracy guaranteed to 0,002mm TIR(0,0001").
- Excellent for grinders and CNC lathes.
- Heat-treated point to HRc 60±2.
- Two angular contact bearings for superior performance.
- Anti-friction seal for coolant deflectors and high speed.
- High RPM, up to 6,000.
- Heat-treated body for extra strength, rigidity and long life.

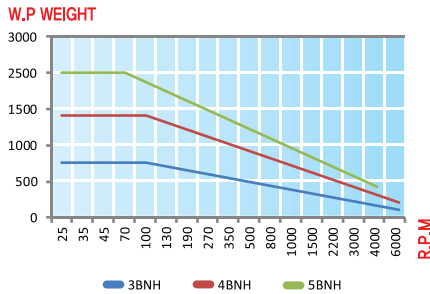

BNH type technical data

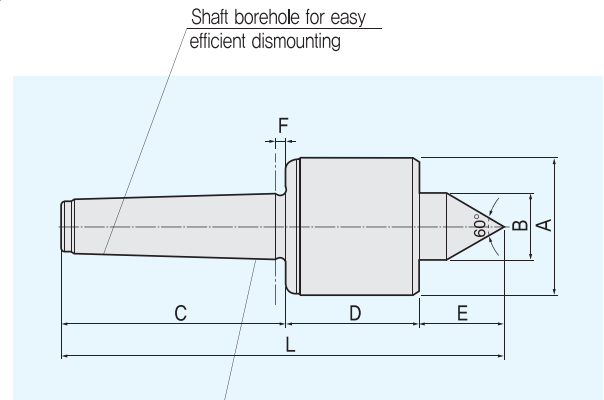

Dimension

03	1	0	0	MT	Unit : mm, kg							
MODEL	MT	A	B	C	D	E	F	L	W.P Weight	Max, R.P.M	Weight	Max, Run Out
031003	3	50	22	85	51.5	26	4.5	162.5	750	6,000	1.8	0.002
031004	4	66	32	108	64	41	5.3	213	1,400	6,000	2.2	0.002
031005	5	80	40	136	70	41	6.3	247	2,500	5,000	5.2	0.002

BNHC-TYPE



FEATURES ;

- Accuracy guaranteed to 0,002mm TIR(0,0001").
- Excellent for grinders and CNC lathes.
- Heat-treated point to HRc 90±5.
- Two angular contact bearings for superior performance.
- Anti-friction seal for coolant deflectors and high speed.
- High RPM, up to 6,000.
- Heat-treated body for extra strength, rigidity and long life.

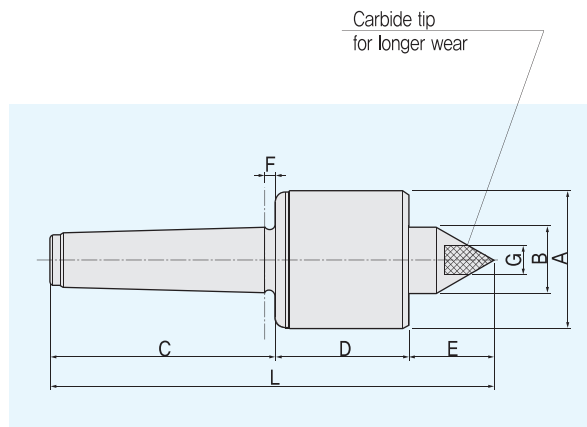

Dimension

03	2	0	0	MT										Unit : mm, kg	
MODEL	MT	A	B	C	D	E	F	G	L	W.P Weight	Max, R,P,M	Weight	Max, Run Out		
032003	3	50	22	85	51.5	26	4.5	10	162.5	750	6,000	1.8	0.002		
032004	4	66	32	108	64	41	5.3	14	213	1,400	6,000	2.2	0.002		
032005	5	80	40	136	70	41	6.3	18	247	2,500	5,000	5.2	0.002		

BNHL30-TYPE



FEATURES ;

- Accuracy guaranteed to 0,002mm TIR(0,0001").
- Excellent for grinders and CNC lathes.
- Heat-treated point to HRc 60±2.
- Three angular contact bearings for superior performance.
- Anti-friction seal for coolant deflectors and high speed.
- High RPM, up to 6,000.
- Heat-treated body for extra strength, rigidity and long life.

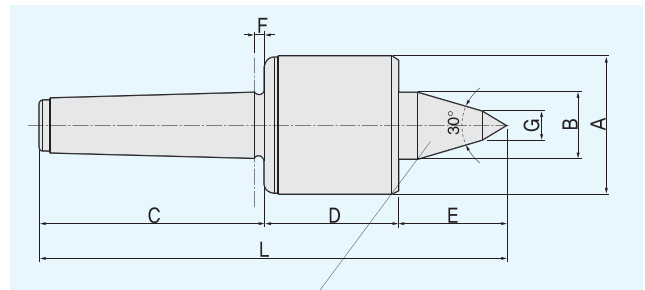
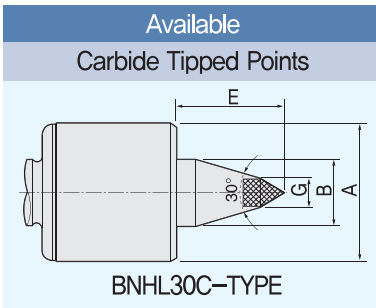

30° point is specially shaped for improved tool clearance

Dimension

03	3	0	0	MT									
MODEL	MT	A	B	C	D	E	F	G	L	W,P Weight	Max, R,P,M	Weight	Max, Run Out
033003	3	50	22	85	51,5	35	4,5	12	171,5	600	6,000	1,9	0,002
033004	4	66	32	108	64	53	5,3	14	225	1,100	6,000	2,2	0,002
033005	5	80	40	136	70	65	6,3	16	271	2,000	5,000	5,2	0,002

Unit : mm, kg

BNHL30A-TYPE



FEATURES ;

- Accuracy guaranteed to 0,002mm TIR(0,0001"),
- Excellent for grinders and CNC lathes.
- Heat-treated point to HRC 60±2,
- Three angular contact bearings for superior performance.
- Anti-friction seal for coolant deflectors and high speed,
- High RPM, up to 6,000,
- Heat-treated body for extra strength, rigidity and long life.

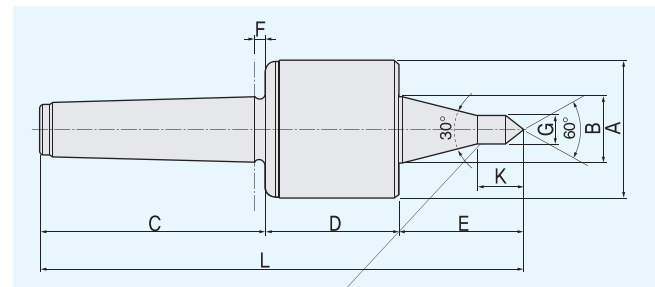
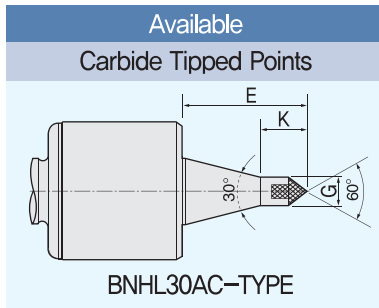

Elongated center point is specially shaped for improved tool clearance(Diagram)

Dimension

03	5	0	0	MT											Unit : mm, kg	
MODEL	MT	A	B	C	D	E	F	G	K	L	W.P Weight	Max, R,P,M	Weight	Max, Run Out		
035003	3	50	22	85	51.5	50	4.5	10	19	181.5	500	6,000	1.9	0,002		
035004	4	66	32	108	64	63.5	5.3	12.5	23.5	235.5	900	6,000	2.2	0,002		
035005	5	80	40	136	70	80	6.3	12.5	23.5	286	1,700	5,000	5.2	0,002		

BS-TYPE



“NEW”

FEATURES ;

- Accuracy guaranteed to 0,002 mm TIR(0,0001”).
- Excellent for grinders and CNC lathes.
- Heat-treated point to HRc 60±2.
- Two angular contact bearings for superior performance.
- Anti-friction seal for coolant deflectors and high speed.
- High RPM, up to 6,000.
- Heat-treated body for extra strength, rigidity and long life.

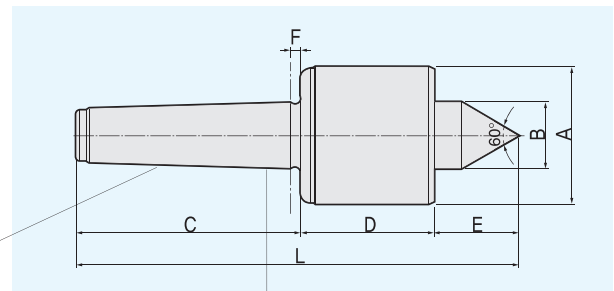

Shaft borehole for easy efficient dismounting

Drop-forged body for long life
HRc. 50±2

Dimension

16	1	0	0	MT								
MODEL	MT	A	B	C	D	E	F	L	W.P Weight	Max, R,P,M	Weight	Max, Run Out
161003	3	50	20	85	58	23	4,5	166	750	6,000	1,9	0,002
161004	4	66	30	108	71	35	5,3	214	1,400	6,000	2,4	0,002
161005	5	80	35	136	76	38	6,3	250	2,500	5,000	5,3	0,002

Unit : mm, kg

BSC-TYPE



“NEW”

FEATURES ;

- Accuracy guaranteed to 0,002mm TIR(0,0001”),
- Excellent for grinders and CNC lathes,
- Heat-treated point to HRc 60±2,
- Two angular contact bearings for superior performance,
- Anti-friction seal for coolant deflectors and high speed,
- High RPM, up to 6,000,
- Heat-treated body for extra strength, rigidity and long life.

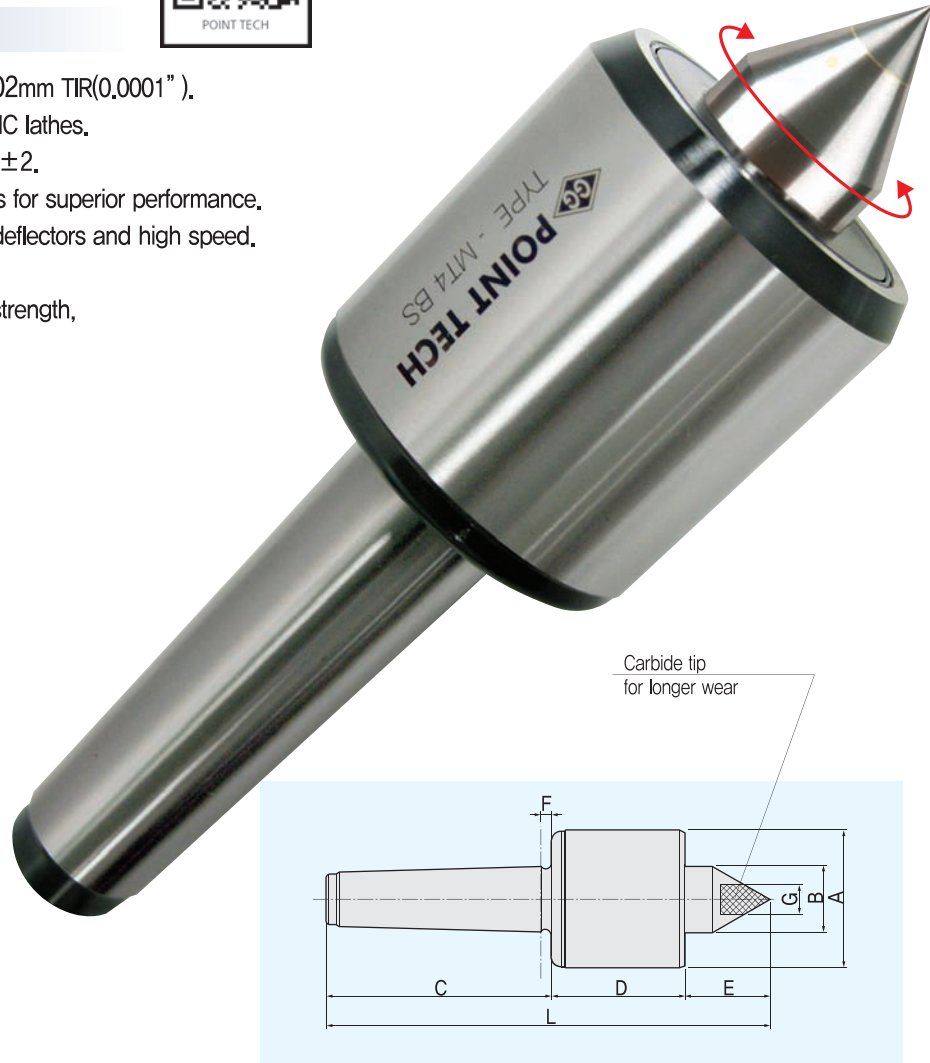

Dimension

16	2	0	0	MT	Unit : mm, kg								
MODEL	MT	A	B	C	D	E	F	G	L	W.P Weight	Max, R,P,M	Weight	Max, Run Out
162003	3	50	22	85	58	23	4,5	10	166	750	6,000	1,9	0,002
162004	4	66	30	108	71	35	5,3	14	214	1,400	6,000	2,4	0,002
162005	5	80	35	136	76	38	6,3	18	250	2,500	5,000	5,3	0,002

BSL30-TYPE



“NEW”

FEATURES ;

- Accuracy guaranteed to 0,002mm TIR(0,0001”).
- Excellent for grinders and CNC lathes.
- Heat-treated point to HRC 60±2,
- Three angular contact bearings for superior performance.
- Anti-friction seal for coolant deflectors and high speed.
- High RPM, up to 6,000.
- Heat-treated body for extra strength, rigidity and long life.

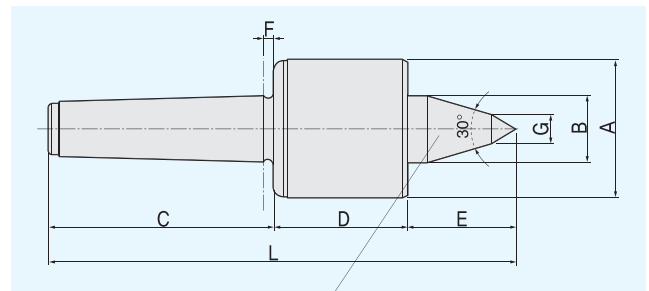
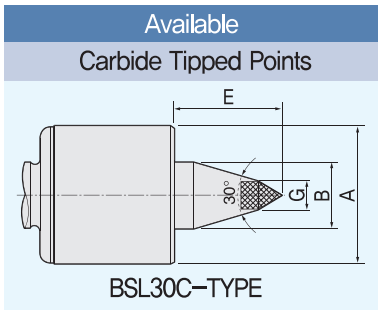

30° point is specially shaped for improved tool clearance

Dimension

16	3	0	0	MT									
MODEL	MT	A	B	C	D	E	F	G	L	W,P Weight	Max, R,P,M	Weight	Max, Run Out
163003	3	50	20	85	58	31	4.5	10	174	750	6,000	1.9	0,002
163004	4	66	30	108	71	51	5.3	14	230	1,400	6,000	2.4	0,002
163005	5	80	35	136	76	53	6.3	18	265	2,500	5,000	5.3	0,002

Unit : mm, kg

BSL30A-TYPE



“NEW”

FEATURES ;

- Accuracy guaranteed to 0,002mm TIR(0,0001”).
- Excellent for grinders and CNC lathes.
- Heat-treated point to HRc 60±2.
- Three angular contact bearings for superior performance.
- Anti-friction seal for coolant deflectors and high speed.
- High RPM, up to 6,000.
- Heat-treated body for extra strength, rigidity and long life

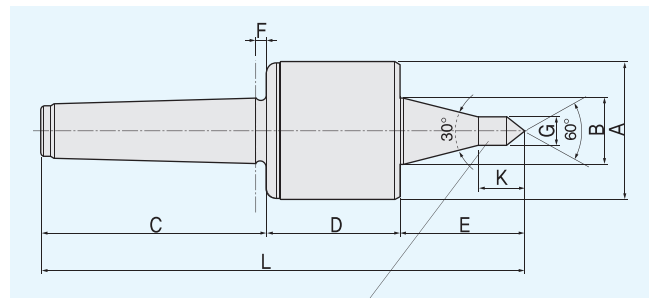
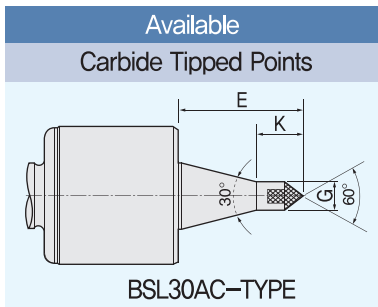
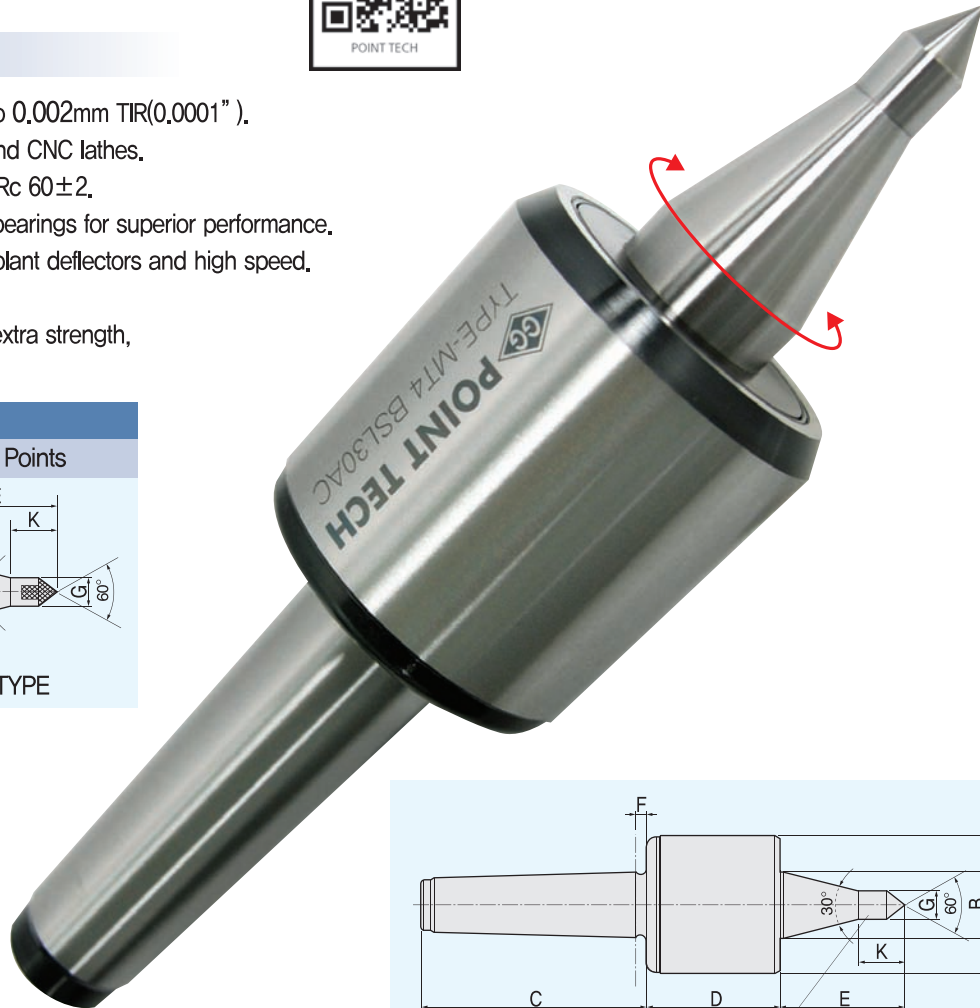

Elongated center point is specially shaped for improved tool clearance(Diagram)

Dimension

16	5	0	0	MT											Unit : mm, kg	
MODEL	MT	A	B	C	D	E	F	G	K	L	W.P Weight	Max, R,P,M	Weight	Max, Run Out		
165003	3	50	20	85	58	37	4.5	10	15	180	750	6,000	1.9	0,002		
165004	4	66	30	108	71	63.5	5.3	12.5	23	242.5	1,400	6,000	2.4	0,002		
165005	5	80	35	136	76	70	6.3	12.5	23.5	282	2,500	5,000	5.3	0,002		

BHS-TYPE



FEATURES ;

- Accuracy guaranteed to 0,002mm TIR(0,0001").
- Excellent for grinders and CNC lathes.
- Heat-treated point to HRC 60±2,
- Three angular contact bearings for superior performance.
- Anti-friction seal for coolant deflectors and high speed.
- High RPM, up to 12,000.
- Heat-treated body for extra strength, rigidity and long life.
- Drain hole have to be located on buttom side.

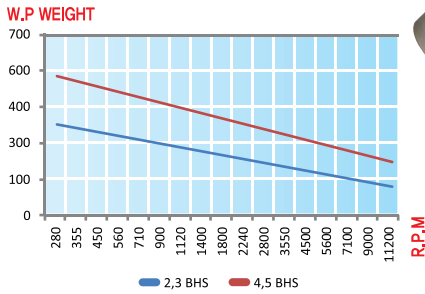

BHS type technical data

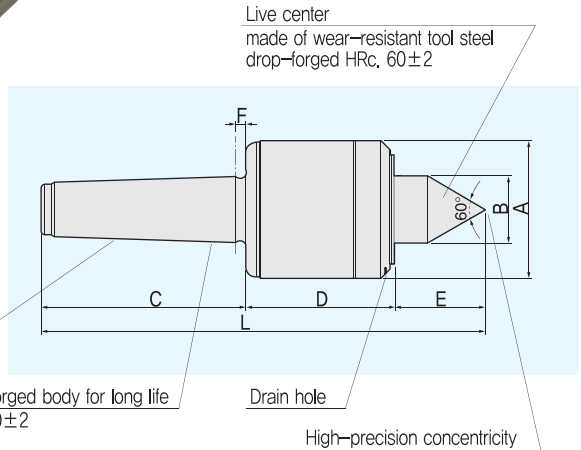

Dimension

04	1	0	0	MT								
MODEL	MT	A	B	C	D	E	F	L	W.P Weight	Max, R,P,M	Weight	Max, Run Out
041002	2	50	20	68	54	26	4	148	360	15,000	1,5	0,002
041003	3	50	20	85	54	26	4,5	165	360	15,000	1,8	0,002
041004	4	70	30	108	75	37	5,3	220	560	12,000	2,2	0,002
041005	5	70	30	136	75	37	6,3	248	560	12,000	5,2	0,002

Unit : mm, kg

BHSC-TYPE



FEATURES ;

- Accuracy guaranteed to 0,002mm TIR(0,0001").
- Excellent for grinders and CNC lathes.
- Heat-treated point to HRc 90±5.
- Three angular contact bearings for superior performance.
- Anti-friction seal for coolant deflectors and high speed.
- High RPM, up to 12,000.
- Heat-treated body for extra strength, rigidity and long life.
- Drain hole have to be located on buttom side.

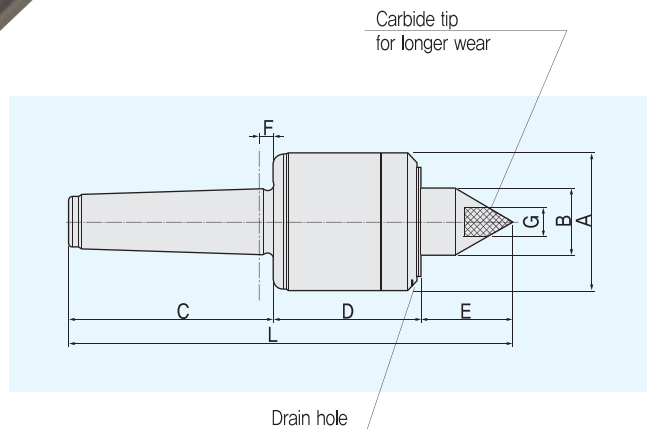

Dimension

04	2	0	0	MT	Unit : mm, kg								
MODEL	MT	A	B	C	D	E	F	G	L	W.P Weight	Max, R.P.M	Weight	Max, Run Out
042002	2	50	20	68	54	26	4	10	148	360	15,000	1,5	0,002
042003	3	50	20	85	54	26	4.5	10	165	360	15,000	1,8	0,002
042004	4	70	30	108	75	37	5.3	14	220	560	12,000	2,2	0,002
042005	5	70	30	136	75	37	6.3	18	248	560	12,000	5,2	0,002

BHSL30-TYPE



FEATURES ;

- Accuracy guaranteed to 0,002mm TIR(0,0001").
- Excellent for grinders and CNC lathes.
- Heat-treated point to HRc 60±2.
- Three angular contact bearings for superior performance.
- Anti-friction seal for coolant deflections and high speed.
- High RPM, up to 12,000.
- Heat-treated body for extra strength, rigidity and long life.
- Drain hole have to be located on bottom side.

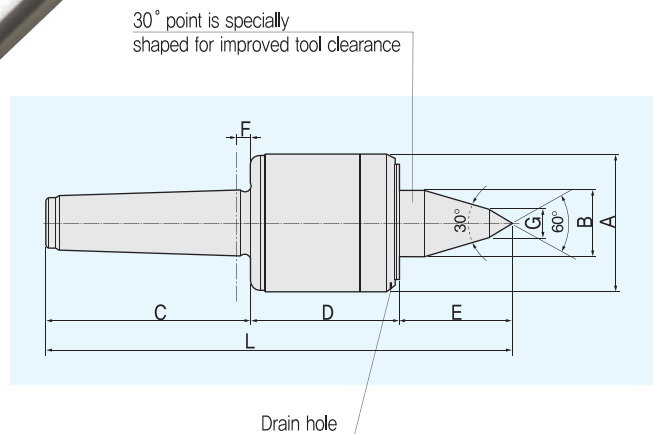
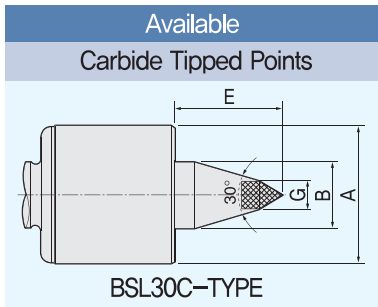

Dimension

04	2	0	0	MT	Unit : mm, kg								
MODEL	MT	A	B	C	D	E	F	G	L	W,P Weight	Max, R,P,M	Weight	Max, Run Out
043002	2	50	20	68	54	35	4	10	157	280	15,000	1.8	0,002
043003	3	50	20	85	54	35	4.5	12	174	280	15,000	1.8	0,002
043004	4	70	30	108	75	53	5.3	14	236	450	12,000	2.2	0,002
043005	5	70	30	136	75	53	6.3	18	264	450	12,000	5.2	0,002

BHSL30A-TYPE



FEATURES ;

- Accuracy guaranteed to 0,002mm TIR(0,0001").
- Excellent for grinders and CNC lathes.
- Heat-treated point to HRC 60±2.
- Three angular contact bearings for superior performance.
- Anti-friction seal for coolant deflections and high speed.
- High RPM, up to 12,000.
- Heat-treated body for extra strength, rigidity and long life.
- Drain hole have to be located on bottom side.

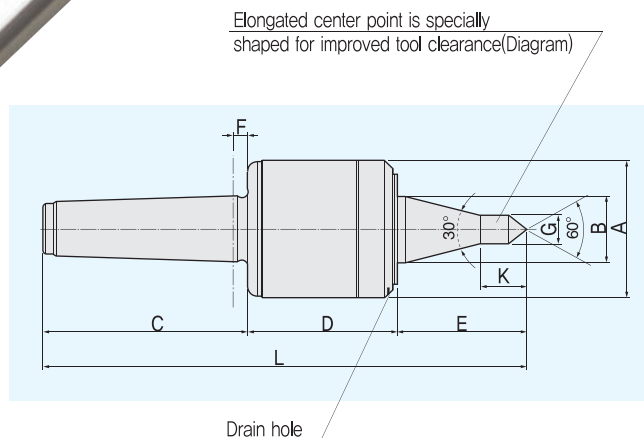
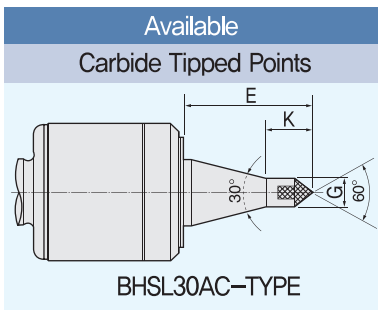

SUPER HIGH SPEED LIVE CENTERS

Dimension

04	5	0	0	MT											Unit : mm, kg	
MODEL	MT	A	B	C	D	E	F	G	K	L	W.P Weight	Max, R,P,M	Weight	Max, Run Out		
045002	2	50	20	68	54	45	4	10	19	167	250	15,000	1,8	0,002		
045003	3	50	20	85	54	45	4,5	10	19	184	250	15,000	1,8	0,002		
045004	4	70	30	108	75	63,5	5,3	12,5	23,5	246,5	390	12,000	2,2	0,002		
045005	5	70	30	136	75	63,5	6,3	12,5	23,5	274,5	390	12,000	5,2	0,002		

BNI-TYPE



FEATURES ;

- Accuracy for center inner diameter guaranteed to 0,003.
- Accuracy after point locking guaranteed to 0,005.
- Excellent for engine lathes and CNC lathes.
- Heat-treated point to HRc 60±2.
- The interchangeable center points are standard point, 75° point, 90° point, extra-long point, pipe point, and female point.
- Because of the insert centers, the admissible workpiece weight is reduced.

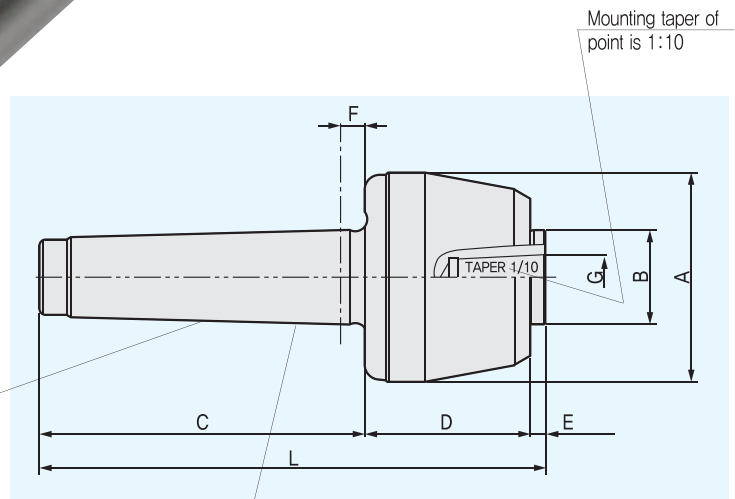

Shaft borehole for easy efficient dismounting

Drop-forged body
HRc. 50±2

Dimension

05	1	0	0	MT										Unit : mm, kg	
MODEL	MT	A	B	C	D	E	F	G	L	W,P Weight	Max, R.P.M	Weight	Max, Run Out		
051002	2	50	25	68	43,5	5	6	12	116,5	80	5,000	0,6	0,005		
051003	3	50	25	85	43,5	5	6	12	133,5	150	5,000	0,8	0,005		
051004	4	69	32	108	55	5	8	15	168	250	3,800	1,7	0,005		
051005	5	88	40	136	70	6	8	22	212	650	3,000	3,9	0,005		

BNI-POINT

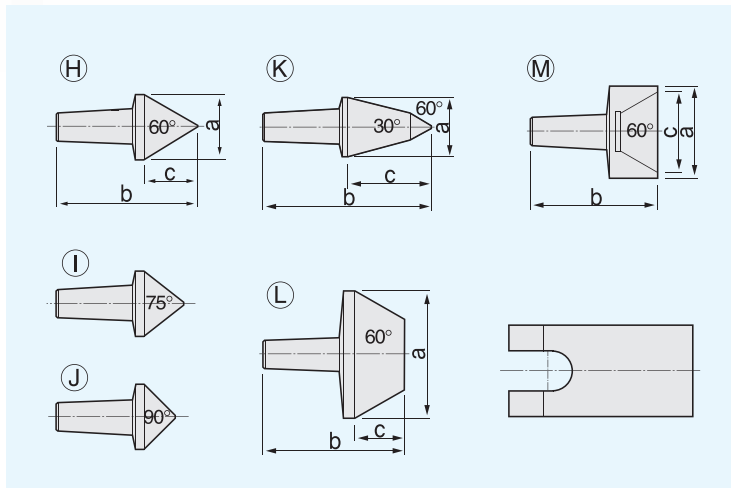

Dimension

Unit : mm, kg

MODEL	MT		H	I	J	K	L	M
051002	2	a	24	24	24	18	45	22
		b	51.5	46.5	43	54	51	60
		c	20	15	11.5	25	17.5	18
051003	3	a	24	24	24	18	45	22
		b	51.5	46.5	43	54	51	60
		c	20	15	11.5	25	17.5	18
051004	4	a	28	28	28	26	55	40
		b	61.5	55.5	51.5	73	61.5	55
		c	23.5	17.5	13.5	36	21.5	35
051005	5	a	38	38	38	32	70	52
		b	78	70	64	90	74	65
		c	32	24	18.5	46	20	45

TN-TYPE



FEATURES ;

- Accuracy guaranteed to 0,003mm TIR (0,0001").
- Excellent for engine lathes and CNC lathes.
- Heat-treated point to HRC 60±2.
- Heavy duty type (The introduction of taper roller bearing assembly)
- Easily pre-load bearings.

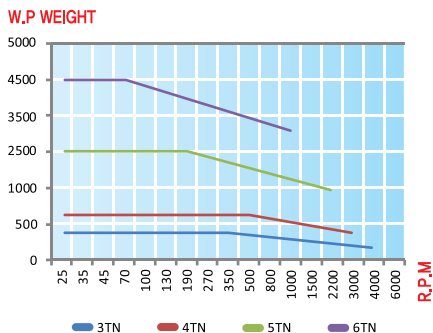

TN type technical data

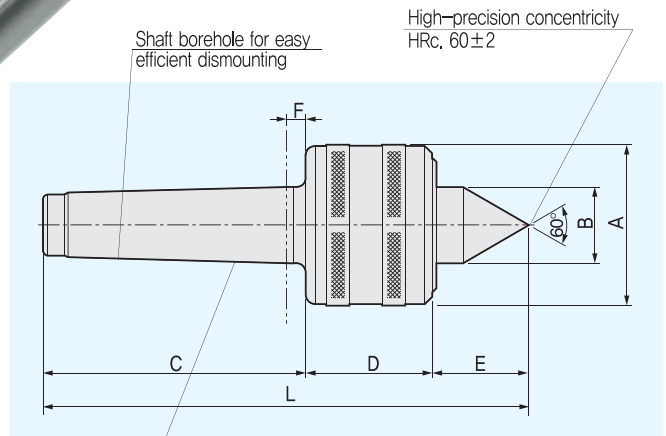

Dimension

06	1	0	0	MT								
MODEL	MT	A	B	C	D	E	F	L	W.P Weight	Max, R.P.M	Weight	Max, Run Out
061003	3	51	25	85	44	28	6	157	400	4,000	0,8	0,003
061004	4	66	32	108	52	40	8	200	650	3,000	1,8	0,003
061005	5	93	40	136	70	43,7	8	249,7	2,500	2,000	4,3	0,003
061006	6	127	58,5	189	92,7	61,5	10	343,3	4,500	1,000	12,5	0,005
061006H	6	168	80	191	120	84	10	395	8,000	800	20	0,005
061007	7	177	78,5	260	110	80	12	450	5,000	500	32	0,010
061008	7	177	78,5	260	124	80	12	464	10,000	500	34	0,010

Unit : mm, kg

TNC-TYPE



FEATURES ;

- Accuracy guaranteed to 0.003mm TIR (0.0001").
- Excellent for engine lathes and CNC lathes.
- Heat-treated point to HRC 90±5.
- Heavy duty type (The introduction of taper roller bearing assembly)
- Easily pre-load bearings.

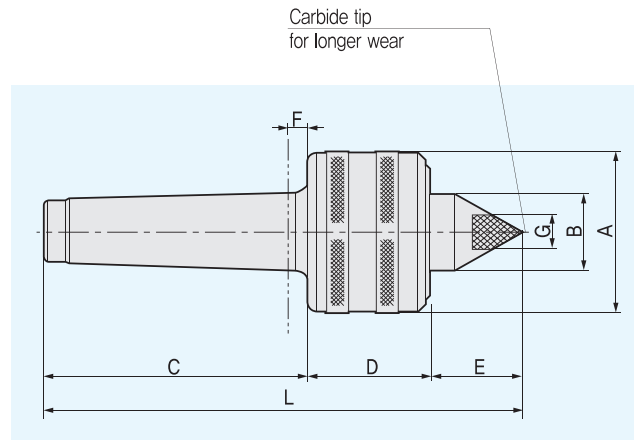

HEAVY DUTY LIVE CENTERS WITH CARBIDE TIPPED POINT

Dimension

06	2	0	0	MT	Unit : mm, kg								
MODEL	MT	A	B	C	D	E	F	G	L	W.P Weight	Max, R.P.M	Weight	Max, Run Out
062003	3	51	25	85	44	28	6	10	157	400	4,000	0.8	0.003
062004	4	66	32	108	52	40	8	14	200	650	3,000	1.8	0.003
062005	5	93	40	136	70	43.7	8	18	249.7	2,500	2,000	4.3	0.003
062006	6	127	58.5	189	92.7	61.5	10	30	343.3	4,500	1,000	12.5	0.005

WP-TYPE



FEATURES ;

- Accuracy guaranteed to 0,003mm TIR (0,0001").
- Excellent for CNC lathe and grinding machine and inspection machine.
- Center point and body are through-hardened to HRc 60±2,
- Small head diameter reduces interference problem between tool holders and turning tools,
- Water proof type.

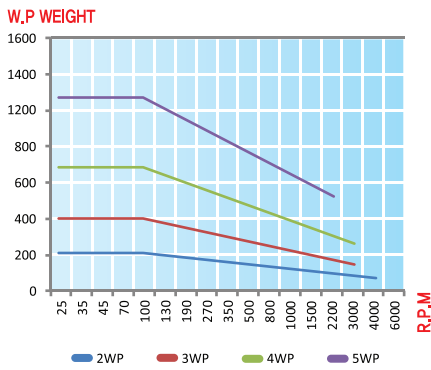

WP type technical data

Live center made of wear-resistant tool steel drop-forged HRc, 60±2

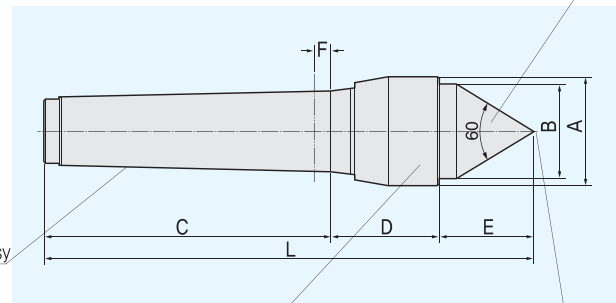

Shaft borehole for easy efficient dismounting HRc, 50±2.

Small head for improved tool clearance

High-precision concentricity

Dimension

07	1	0	0	MT								
MODEL	MT	A	B	C	D	E	F	L	W.P Weight	Max, R.P,M	Weight	Max, Run Out
071002	2	27.7	23.8	69	28	23	4.5	120	200	4,000	0.3	0.003
071003	3	32.3	28	85	32	28	5	145	400	3,000	0.4	0.003
071004	4	45	40	108	48	38	6	194	700	3,000	1.1	0.003
071005	5	62	54	136	54	51	8	241	1300	2,000	2.7	0.003

Unit : mm, kg

WPC-TYPE



FEATURES ;

- Accuracy guaranteed to 0,003mm TIR (0,0001").
- Excellent for CNC lathe and grinding machine and inspection machine.
- Center point and body are through-hardened to HRc 60±2.
- Small head diameter reduces interference problem between tool holders and turning tools.
- Water proof type.



Carbide tip for longer wear

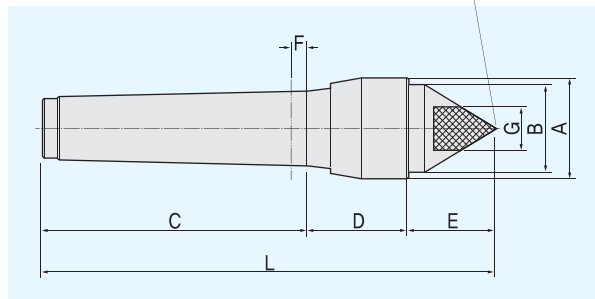

Dimension

07	2	0	0	MT	Unit : mm, kg								
MODEL	MT	A	B	C	D	E	F	G	L	W.P Weight	Max, R.P.M	Weight	Max, Run Out
072002	2	27.7	23.8	69	28	23	4.5	10	120	200	4,000	0,3	0,003
072003	3	32.3	28	85	32	28	5	10	145	400	3,000	0,4	0,003
072004	4	45	40	108	48	38	6	14	194	700	3,000	1,1	0,003
072005	5	62	54	136	54	51	8	18	241	1,300	2,000	2,72	0,003

WPL30-TYPE



FEATURES ;

- Accuracy guaranteed to 0,003mm TIR (0,0001").
- Excellent for CNC lathe and grinding machine and inspection machine.
- Center point and body are through-hardened to HRC 60±2.
- Small head diameter reduces interference problem between tool holders and turning tools.
- Water proof type.

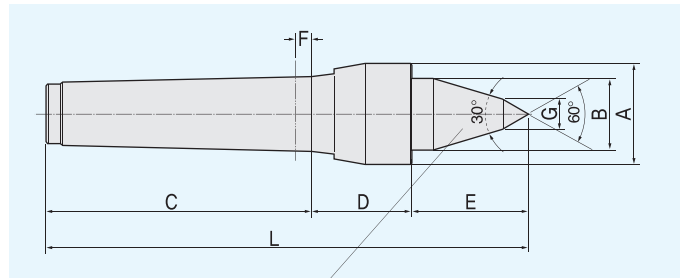
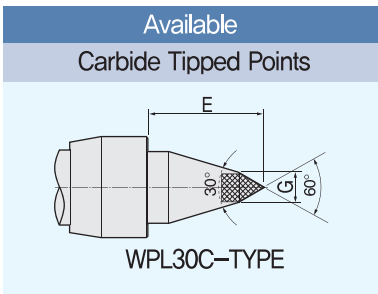

30° point is specially shaped for improved tool clearance

Dimension

07	3	0	0	MT									
MODEL	MT	A	B	C	D	E	F	G	L	W,P Weight	Max, R,P,M	Weight	Max, Run Out
073002	2	27.7	23.8	69	28	35	4.5	10	132	120	4,000	0.3	0,003
073003	3	32.3	28	85	32	45	5	10	162	320	3,000	0.5	0,003
073004	4	45	40	108	48	65	6	14	221	560	3,000	1.2	0,003
073005	5	62	54	136	54	90	8	16	280	1,000	2,000	3.2	0,003

Unit : mm, kg

WPL30A-TYPE



FEATURES ;

- Accuracy guaranteed to 0,003mm TIR (0,0001").
- Excellent for CNC lathe and grinding machine and inspection machine.
- Center point and body are through-hardened to HRC 60±2.
- Small head diameter reduces interference problem between tool holders and turning tools.
- Water proof type.

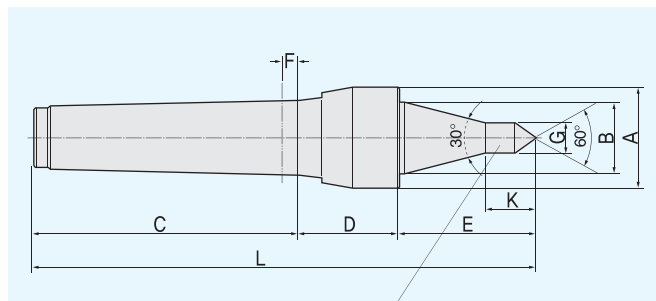
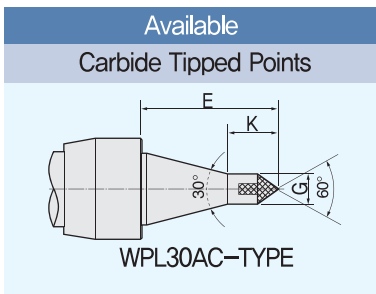

Elongated center point is specially shaped for improved tool clearance(Diagram)

Dimension

07	5	0	0	MT											Unit : mm, kg	
MODEL	MT	A	B	C	D	E	F	G	K	L	W.P Weight	Max, R.P.M	Weight	Max, Run Out		
075002	2	27.7	23.8	69	28	42	4.5	10	14	139	100	4,000	0.3	0.003		
075003	3	32.3	28	85	32	50	5	10	14	167	280	3,000	0.5	0.003		
075004	4	45	40	108	48	80	6	12.5	24	236	500	3,000	1.2	0.003		
075005	5	62	54	136	54	110	8	12.5	24	300	900	2,000	3.2	0.003		

BP60-TYPE



FEATURES ;

- Accuracy guaranteed to 0,003mm TIR (0,0001").
- Excellent for engine lathes and CNC lathe.
- The interior houses a combination of double row angular contact bearing, thrust bearing, and radial ball bearing.
- Used both as a centering taper for hollow bodies and as a center for machining standard work-piece.



W.P WEIGHT

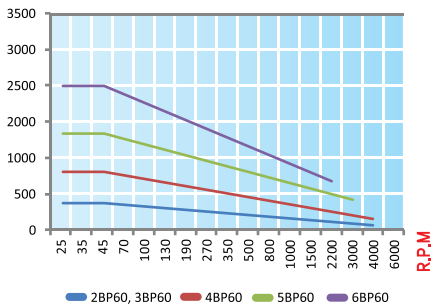

BP60 type technical data

Shaft borehole for easy efficient dismounting HRc, 50±2

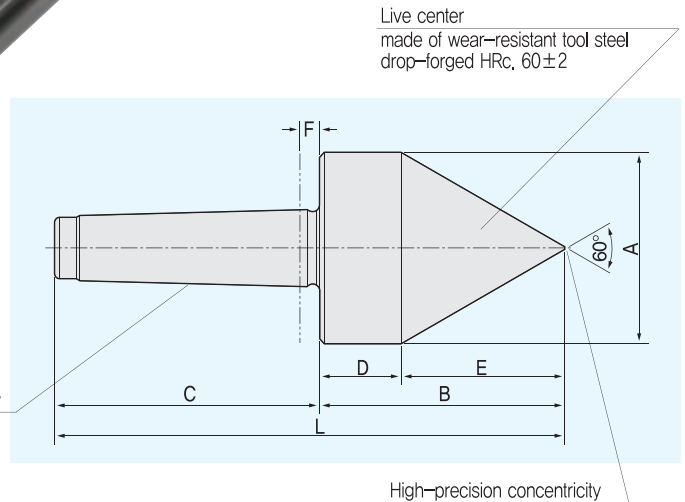

Dimension

08	1	0	0	MT								
MODEL	MT	A	B	C	D	E	F	L	W.P Weight	Max, R.P,M	Weight	Max, Run Out
081002	2	44	66	68	28	38	6	134	400	5,000	1,5	0,003
081003	3	56	78,5	85	30	48,5	6	163,5	400	5,000	1,5	0,003
081004	4	78	100	108	33,3	66,7	8	208	800	4,500	2,3	0,003
081005	5	98	125	136	41	84	8	261	1,600	3,200	5	0,003
081006	6	118	154	189	53	101	10	343	2,500	2,500	11,2	0,005

Unit : mm, kg

BP60A-TYPE



FEATURES ;

- Accuracy guaranteed to 0,003mm TIR (0,0001").
- Excellent for engine lathes and CNC lathe.
- The interior houses a combination of double row angular contact bearing, thrust bearing, and radial ball bearing.
- Used both as a centering taper for hollow bodies and as a center for machining standard workpiece.

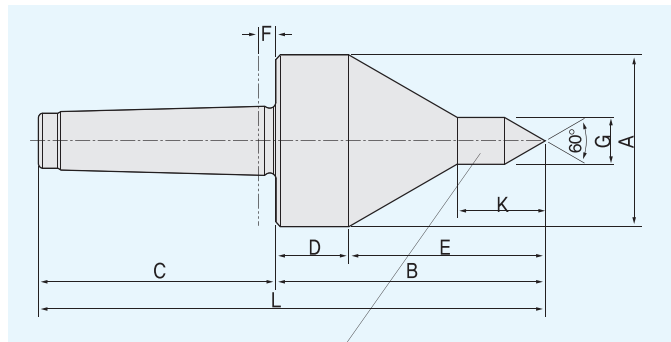

Elongated center point is specially shaped for improved tool clearance(Diagram)

Dimension

08	5	0	0	MT										
MODEL	MT	A	B	C	D	E	F	K	G	L	W,P Weight	Max, R,P,M	Weight	Max, Run Out
085002	2	44	79	68	32.3	46.7	6	19	12	147	320	5,000	1.0	0.003
085003	3	56	86	85	28.9	57.1	6	19	12	171	320	5,000	1.0	0.003
085004	4	78	103.5	108	26.3	77.2	8	23.5	16	211.5	560	4,500	2.3	0.003
085005	5	98	140	136	41.6	98.4	8	30	19	276	1,200	3,200	5	0.003
085006	6	118	165	189	44.3	120.7	10	35	19	354	2,000	2,500	10	0.005

Unit : mm, kg

BP80-TYPE



FEATURES ;

- Accuracy guaranteed to 0,003mm TIR (0,0001").
- Excellent for heavy duty lathe applications.
- The interior houses a combination of taper roller bearing, thrust bearing, and high-precision radial ball bearing.
- The design prevents ingress of coolant and chips.
- For pipe work, tube work, and parts with extra-large center holes.

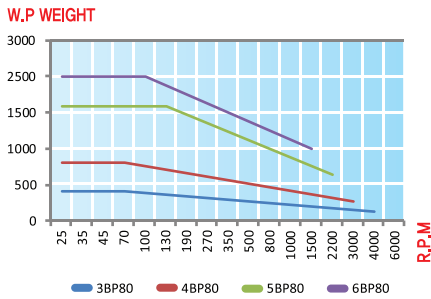

BP80 type technical data

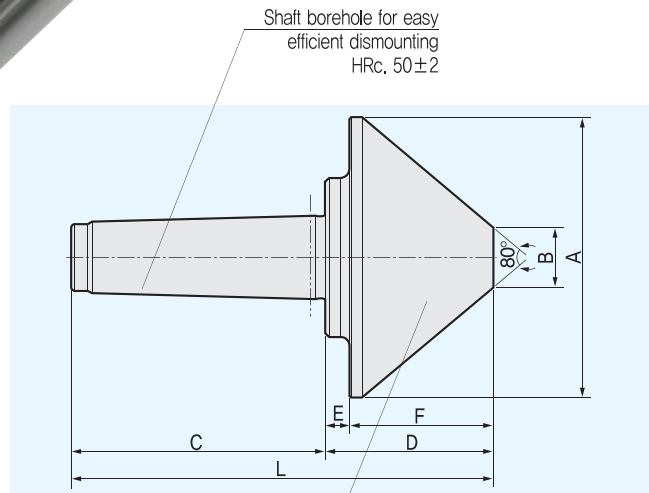

Large size head is available
made of wear-resistant tool steel
drop-forged HRc. 60±2

Dimension

08	3	0	0	MT								
MODEL	MT	A	B	C	D	E	F	L	W.P Weight	Max, R.P.M	Weight	Max, Run Out
083003	3	95	20	85	60	10	50	145	400	4,000	2.4	0.003
083004	4	125	29	108	77	13	64	185	800	3,000	3.9	0.003
083005	5	150	32	136	90	13	77	226	1,600	2,000	6.9	0.003
083006	6	200	38	189	120	15	105	309	2,500	1,500	17	0.005

Unit : mm, kg

DEAD CENTER



FEATURES ;

- Accuracy guaranteed to 0,002mm TIR (0,0001").
- Through-hardened to HRc 60±2,
- Works on all CNC machines,
- Meets the rigid requirements of CNC turning and Grinding machine,
- Excellent for Built-in tail stock,

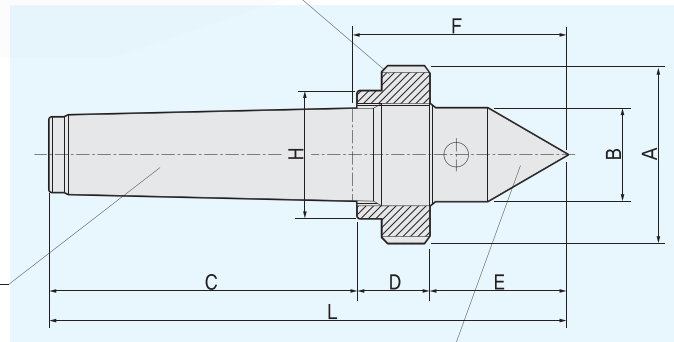
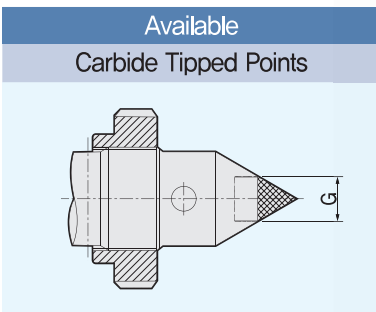

Made of wear-resistant tool steel drop-forged HRc. 60±2

Dimension

13	1	0	0	MT							Unit : mm, kg
MODEL	MT	A	B	C	D	E	F	H	G	L	
131003	3	50	24	82	16	42	59	40	10	140	
131004	4	60	32	104	24	47	72,5	43	14	175	
131005	5	80	45	131	30	60	93	58	18	221	
131006	6	100	60	187	30	72	107	78	30	289	

FACE DRIVER



FEATURES ;

- Complete OD machining in one clamping.
- Heavy cuts with no slippage.
- Greater accuracy in machining operations.
- Accurate end location.
- Faster loading time.
Greater time save in mass production.
- Wide range clamping capability.
- Able to use at Head stock instead of clamping chuck.

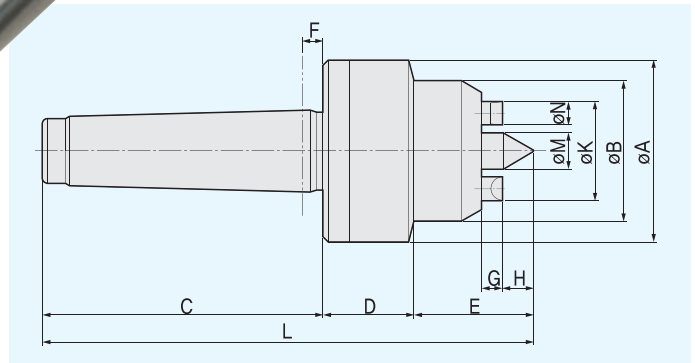

Dimension

09 1 0 0 MT																Unit : mm, kg	
MODEL	MODEL NO.	MT	A	B	C	D	E	F	G	H	L	K	M	N	Number of driving pins	Work size	W.P Weight
FD31	090803	3	42	30	89	24,5	29,5	6	5	4,3	143	17	5	5	4	ø19~ø34	50
	090804	4	42	30	108	24,5	29,5	8	5	4,3	163	17	5	5	4	ø19~ø34	50
	090805	5	42	30	136	24,5	29,5	8	5	4,3	191	17	5	5	4	ø19~ø34	50
FD32	090903	3	52	40	89	26,5	35,8	6	6,5	7,8	150,3	26	9	7	5	ø28~ø50	55
	090904	4	52	40	108	26,5	35,8	8	6,5	7,8	170,3	26	9	7	5	ø28~ø50	55
	090905	5	52	40	136	26,5	35,8	8	6,5	7,8	198,3	26	9	7	5	ø28~ø50	55
FD33	091003	3	70	54	89	36	45	6	9	11	170	38	14	9	6	ø40~ø72	65
	091004	4	70	54	108	36	45	8	9	11	189	38	14	9	6	ø40~ø72	65
	091005	5	70	54	136	36	45	8	9	11	217	38	14	9	6	ø40~ø72	65
FD34	091104	4	82	72	108	40	56,1	8	11	14,1	204,1	54	20	14	6	ø55~ø100	100
	091105	5	82	72	136	40	56,1	8	11	14,1	232,1	54	20	14	6	ø55~ø100	100

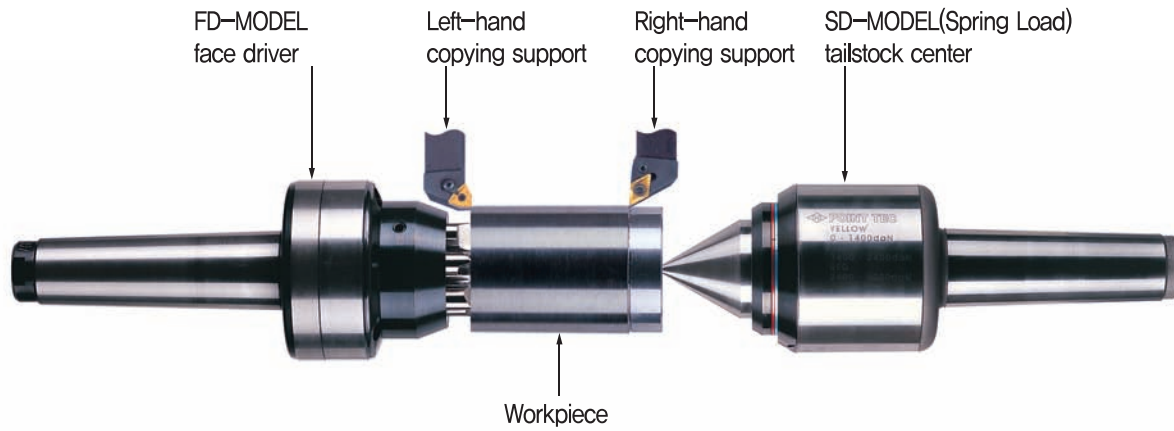

■ Special drive pin styles

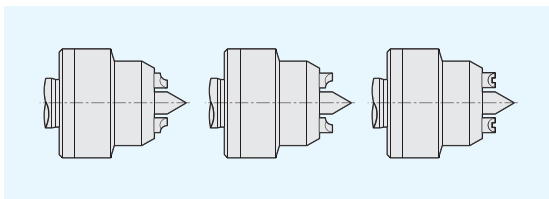

■ Driving pins direction of rotation

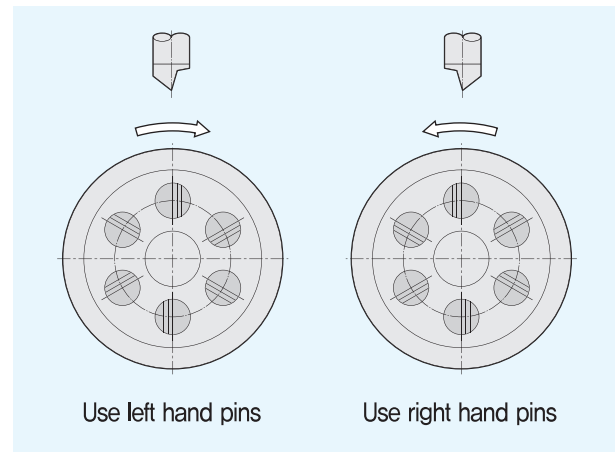

■ Center hole size

NO	MODEL	CENTER HOLE DIA. LIMITS			
		MIN(ϕ)		MAX(ϕ)	
		inch	ϕ	inch	ϕ
1	FD31	0.08	2	0.16	4
2	FD32	0.16	4	0.31	8
3	FD33	0.16	6	0.47	12
4	FD34	0.31	8	0.63	16

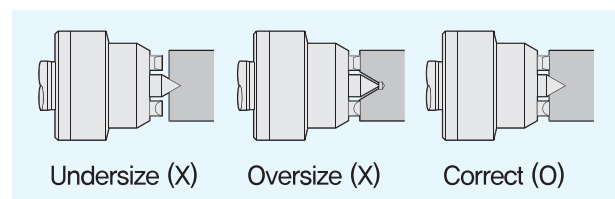

■ The construction of face driver

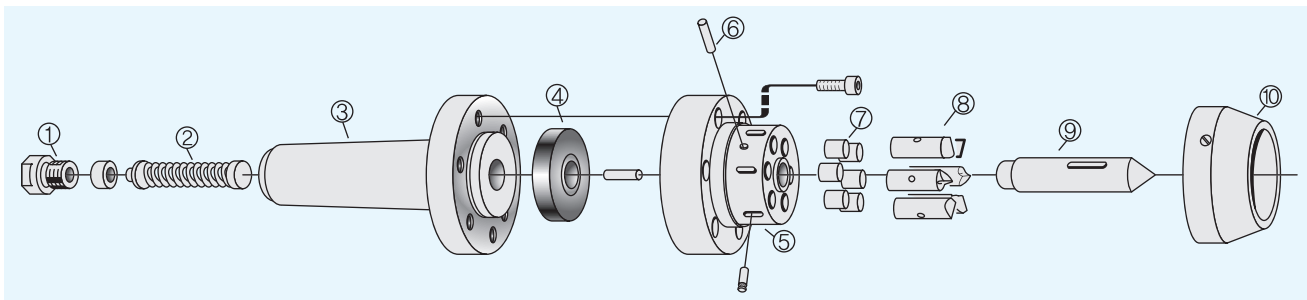

① End cover ② Spring rod ③ Shank ④ SP urethane ⑤ Head ⑥ Pin at Pin ⑦ Roller ⑧ Drive pin ⑨ Point ⑩ Cover

SD-TYPE



FEATURES ;

- Accuracy guaranteed to 0,003mm TIR (0,0001").
- Excellent complement to Face Driver.
- The axial force can easily be read off from a colored ring around the rotor.
- Automatic thrust adjustment and Quick operation.
- The high load dish spring is used to compensate for length variations in the work parts, as well as depth variations in the center holes of the work parts.
- Drain hole have to be located on bottom side.

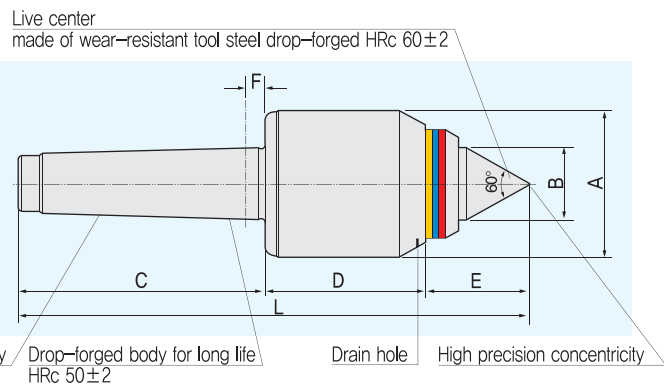
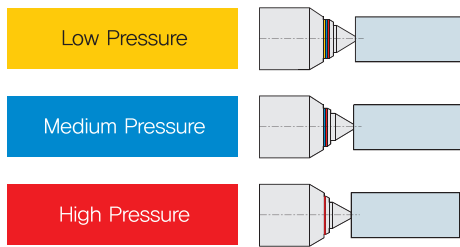
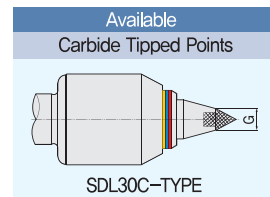
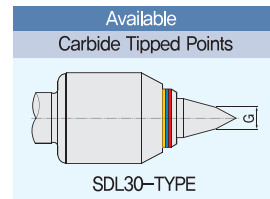
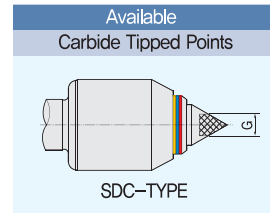

Dimension

10	1	0	0	MT	SD-TYPE	Unit : mm, kg						
MODEL	MT	A	B	C	D	E	F	G	L	W,P Weight	Max, R.P.M	Max, Run Out
101002	2	45	22	68	49	28	6	10	145	400	5,000	0,003
101003	3	52	25	85	54	32	6	10	171	700	4,000	0,003
101004	4	65	32	108	70	45	8	14	223	1,200	3,000	0,003
101005	5	77	40	136	82	52	10	16	270	2,000	2,000	0,003

10	2	0	0	MT	SDL30-TYPE	Unit : mm, kg						
MODEL	MT	A	B	C	D	E	F	G	L	W,P Weight	Max, R.P.M	Max, Run Out
102002	2	45	22	68	49	49	6	10	157	320	5,000	0,003
102003	3	52	25	85	54	50	6	10	189	560	4,000	0,003
102004	4	65	32	108	70	62	8	14	240	960	3,000	0,003
102005	5	77	40	136	82	72	10	16	290	1,600	2,000	0,003

BB-TYPE



FEATURES :

- Accuracy guaranteed to 0,003mm TIR (0,0001").
- Excellent for light/medium-duty work on engine lathe.
- Heat-treated point to HRc 60±2.
- Two radial ball bearings and thrust bearing provide good overall load ratings.
- Rear bearing is sealed, protecting assembly from coolant and chips.

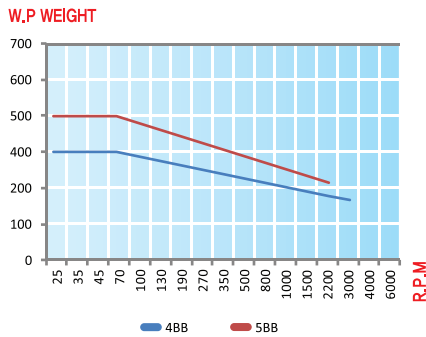
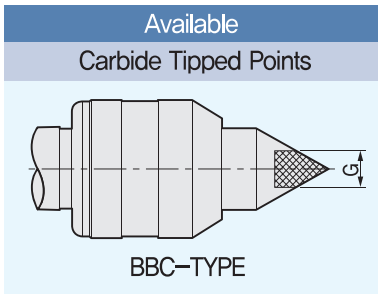

BB type technical data

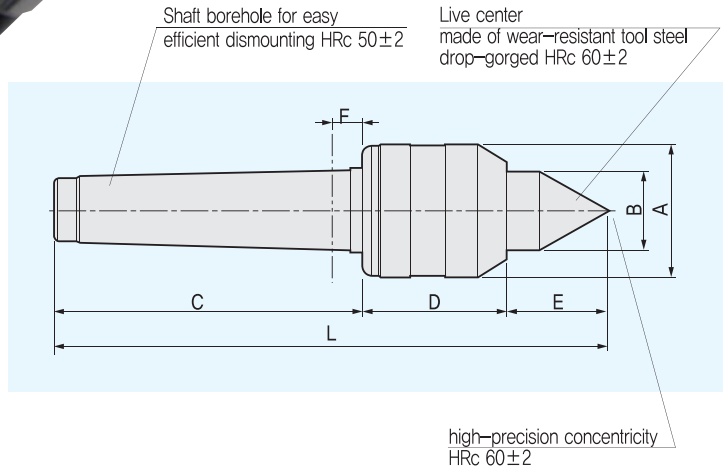

Dimension

12	1	0	0	MT	Unit : mm, kg								
MODEL	MT	A	B	C	D	E	F	G	L	W,P Weight	Max, Axial Load	Max, R.P.M	Max, Run Out
121004	4	44.5	25	108	44	32.5	5.3	12	184.5	400	600	5,000	0,003
121005	5	63	28	136	58	35	6.3	14	229	500	750	4,000	0,003

BBL30-TYPE



FEATURES ;

- Accuracy guaranteed to 0,003mm TIR (0,0001").
- Excellent for light/medium-duty work on engine lathe.
- Heat-treated point to HRc 60±2,
- Two radial ball bearings and thrust bearing provide good overall load ratings.
- Rear bearing is sealed, protecting assembly from coolant and chips.

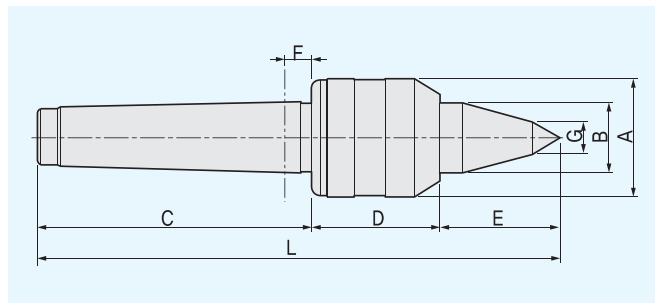
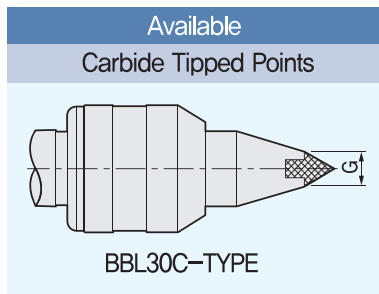

Dimension

12	1	0	0	MT									
MODEL	MT	A	B	C	D	E	F	G	L	W.P Weight	Max, Axial Load	Max, R.P.M	Max, Run Out
122004	4	44.5	22	108	44	36	5.3	12	188	320	600	5,000	0.003
122005	5	63	28	136	58	44	6.3	14	236	400	750	4,000	0.003

Unit : mm, kg

HS-TYPE



FEATURES ;

- Accuracy guaranteed to 0,010mm.
- Excellent for very heavy duty work on engine lathe and CNC lathe.
- Heat-treated point to HRc 60±2.
- Two double-row cylindrical roller bearings and spherical roller thrust bearings support the primary load area of the point.
- Hardened point and body for extra strength, rigidity, and long life.

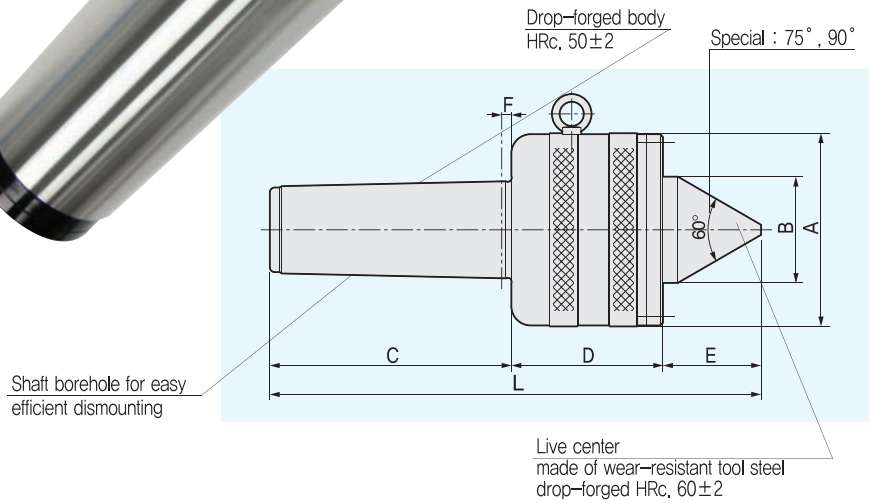

Dimension

14	1	0	0	TEPER									Unit : mm, kg	
MODEL	TAPER	A	B	C	D	E	F	L	W.P Weight	Max, R.P.M	Weight	Max, Run Out		
HS80	1/10	178	110	203	154	96.1	10	453.1	10,000	650	35	0,010		
HS100	1/10	198	110	250	157	101.5	15	508.5	15,000	500	48.3	0,010		
HS110	1/10	238	125	365	162.5	121.5	15	649	20,000	500	60	0,010		
HS120	1/10	238	125	293	162.5	121.5	15	577	20,000	500	58	0,010		
HS80	1/20	178	110	203	154	96.1	10	453.1	10,000	650	36.2	0,010		
HS100	1/20	198	110	250	157	101.5	15	508.5	15,000	500	49.5	0,010		
HS110	1/20	238	125	365	162.5	121.5	15	649	20,000	500	60	0,010		
HS120	1/20	238	125	293	162.5	121.5	15	577	20,000	500	58	0,010		

HSN-TYPE



FEATURES ;

- Accuracy guaranteed to 0,010mm.
- Excellent for very heavy duty work on engine lathe and CNC lathe.
- Heat-treated point to HRc 60±2.
- Two double-row cylindrical roller bearings and spherical roller thrust bearings support the primary load area of the point.
- Hardened point and body for extra strength, rigidity, and long life.
- Draw-off nut type. (Help to easy release from tail-stock)

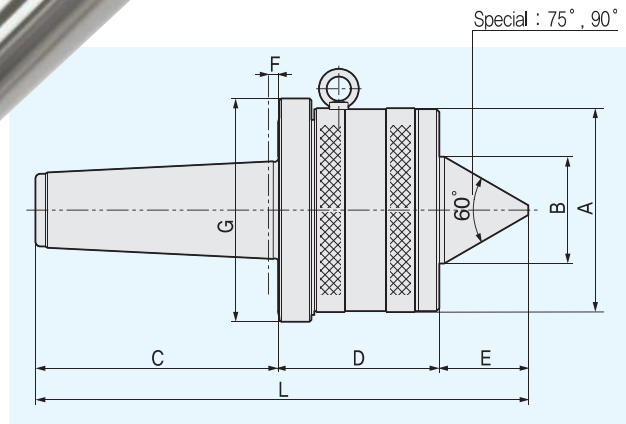

Dimension

14	1	0	0	TEPER										Unit : mm, kg	
MODEL	TAPER	A	B	C	D	E	F	G	L	W,P Weight	Max, R,P,M	Weight	Max, Run Out		
HSN80	1/10	178	110	203	154	96.1	10	200	453.1	10,000	650	34	0.010		
HSN100	1/10	198	110	250	157	101.5	15	230	508.5	15,000	500	53.3	0.010		
HSN110	1/10	238	125	365	162.5	121.5	15	250	649	20,000	500	60	0.010		
HSN120	1/10	238	125	293	162.5	121.5	15	250	577	20,000	500	58	0.010		
HSN80	1/20	178	100	203	154	96.1	10	200	453.1	100,000	650	35.2	0.010		
HSN100	1/20	198	100	250	157	101.5	15	230	508.5	15,000	500	54.5	0.010		
HSN110	1/20	238	125	365	162.5	121.5	15	250	649	20,000	500	60	0.010		
HSN120	1/20	238	125	293	162.5	121.5	15	250	577	20,000	500	58	0.010		

GG



POINT TECH CO., LTD.

KOREA : 292, Cheomdan yeonsin-ro, Buk-gu,
Gwangju, Korea

TEL : 82-62-942-0451 FAX : 82-62-941-1330

http : //www.pointtec.com

E-mail : point@pointtec.com

본사 공장 : 광주광역시 북구 첨단 연신로 292

TEL : 82-62-942-0451 FAX : 82-62-941-1330

E-mail : point@pointtec.com